

Sludge Trap - 615 Gallons

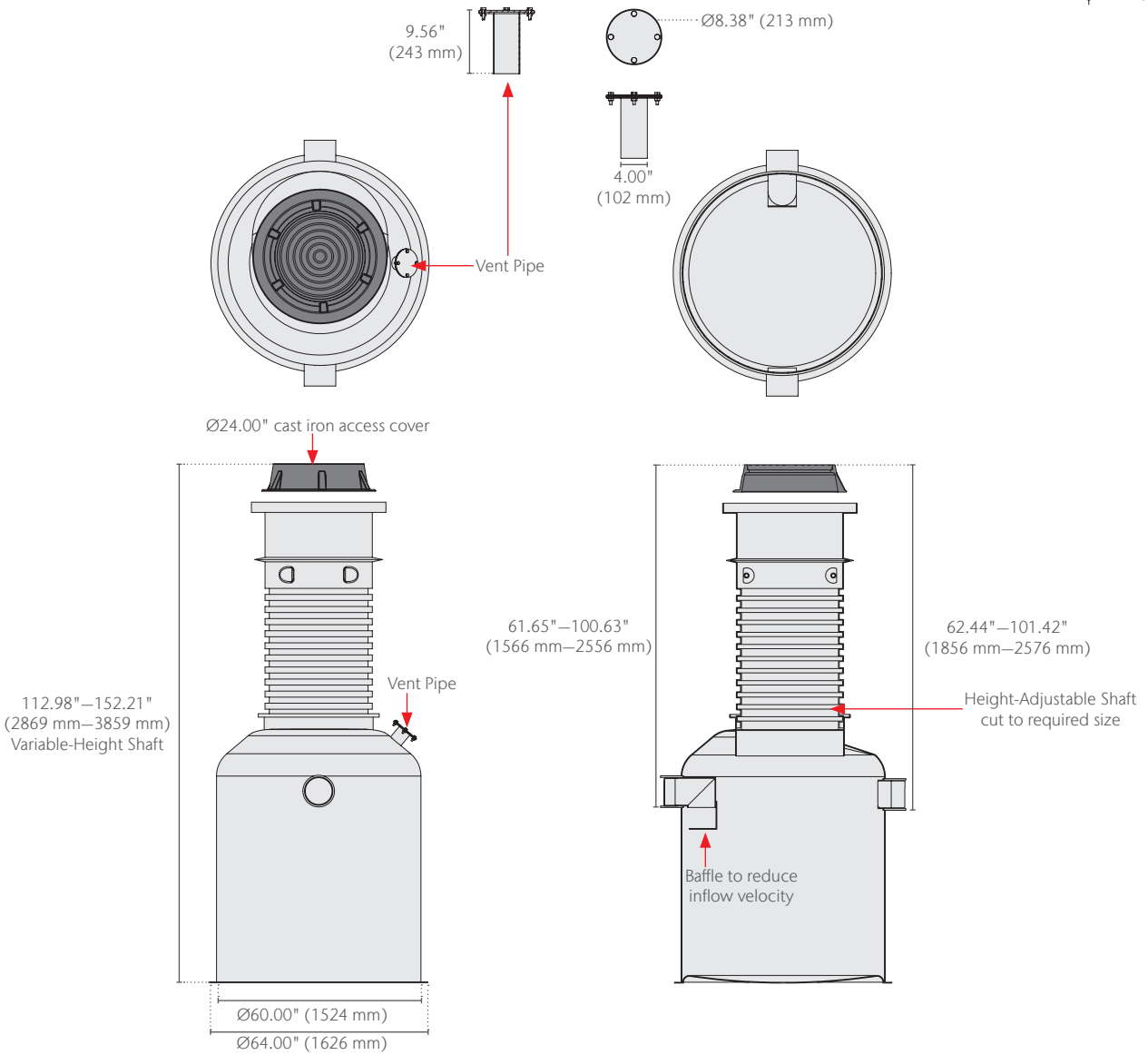

The Sludge Trap is part of a 4-unit bypass separator system. For information on the additional units please contact ACO.

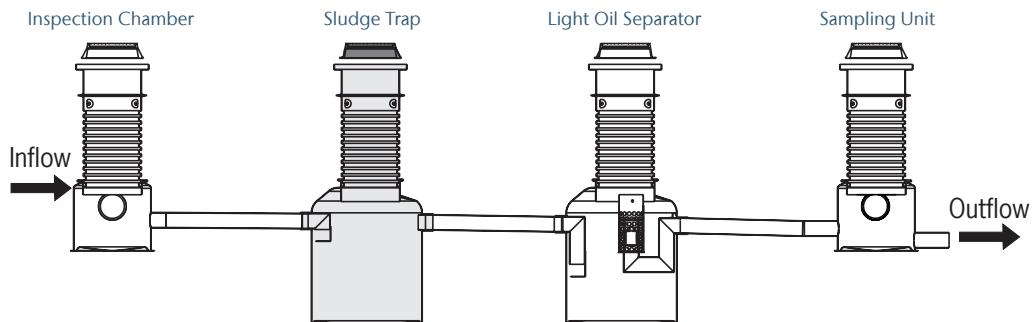

ACO Environment

Sludge Trap - 615 Gallons



Sludge Trap Size Gallons/Piped	Unit Øin (mm)	Pipe Size Øin (mm)	Manhole Cover Øin (mm)	Sludge Capacity gal (L)	Weight lbs
615-8	60.00 (1524)	8.00 (203)	24.00 (610)	615 (2328)	1185.0

Specification Summary

General

The sludge trap element of the bypass separator system shall be ACO Environment Oleopator Sludge Trap as manufactured by ACO, Inc. or equal approved.

Access Cover

A solid cast iron cover of 24.00" (600 mm) diameter and frame are supplied to provide access into the sludge chamber for maintenance. Complies with AASHTO M306-05.

Installation

The separator system shall be installed in accordance with the manufacturer's installation instructions and recommendations.

Materials

The sludge trap body shall be manufactured from fiberglass, with minimum properties as follows:

- Compressive strength: 24,400 psi
- Flexural strength: 9,943 psi
- Water absorption 0.33%
- Frost proof
- Salt proof
- Dilute acid and alkali resistant

The nominal body diameter shall be 60.00" (1524 mm) with overall width of 64.00" (1626 mm). Units shall be manufactured with a wall thickness of at least 0.125" (3 mm). Each unit will feature an extension collar to provide adjustable overall height from 112.98" (2869 mm) up to 151.96" (3859 mm) that can be cut to size on site to suit local requirements. The body shall be manufactured with vent pipe and 8.00" (200 mm) diameter inlet and outlet pipes and shall offer up to 615 gallons of sludge capacity.

An optional alarm system is available to provide audio, visual and/or SMS alerts to ensure maintenance can be carried out before the separator system fails. Required for compliance with UL 2215.

ACO, Inc.

© January 2026 ACO, Inc.

All reasonable care has been taken in compiling the information in this document. All recommendations and suggestions on the use of ACO products are made without guarantee since the conditions of use are beyond the control of the company. It is the customer's responsibility to ensure that each product is fit for its intended purpose and that the actual conditions of use are suitable. ACO, Inc. reserves the right to change products and specifications without notice.

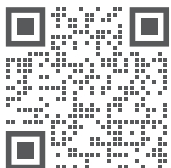

info@acousa.com
www.acousa.com

